



PCT/AU2004/000964

REC'D 04 AUG 2004

WIPO

PCT

**PRIORITY  
DOCUMENT**

SUBMITTED OR TRANSMITTED IN  
COMPLIANCE WITH RULE 17.1(a) OR (b)

**Patent Office  
Canberra**

I, LEANNE MYNOTT, MANAGER EXAMINATION SUPPORT AND SALES hereby certify that annexed is a true copy of the Provisional specification in connection with Application No. 2004900978 for a patent by PALTRONICS AUSTRALASIA PTY LIMITED as filed on 26 February 2004.

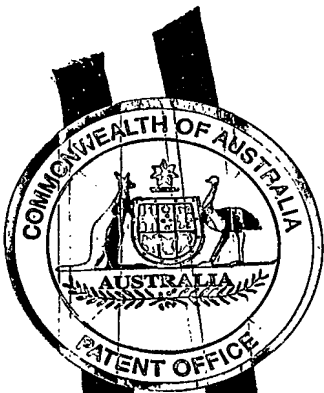

WITNESS my hand this  
Twenty-eighth day of July 2004

**LEANNE MYNOTT**  
**MANAGER EXAMINATION SUPPORT**  
**AND SALES**

**AUSTRALIA**

---

**PATENTS ACT 1990**

---

**PROVISIONAL SPECIFICATION**

***FOR THE INVENTION ENTITLED:-***

**" A METHOD OR APPARATUS FOR ALLOCATING A PLAYER'S  
CONTRIBUTION IN A GAMING APPARATUS BETWEEN A PLURALITY OF  
GAMES "**

The invention is described in the following statement:-

## FIELD OF THE INVENTION

The present invention relates to a method or apparatus for allocating a  
5 player's contribution in a gaming apparatus between a plurality of games.

The invention has been developed primarily for use with a plurality of  
interlinked gaming terminals in one or more gaming establishments and will be  
described hereinafter predominantly with reference to this application.  
10 However, the invention is not limited to that particular field of use and is also  
suitable for use with online gaming, lotto, pools, lotteries, art unions, bingo,  
raffles and other games involving one or more wagers being placed upon an  
outcome having a finite probability of occurring. Additionally, the invention is  
applicable to any type of gaming, such as gaming that may be entered into on  
15 a personal computer via the Internet, for example.

## BACKGROUND

The discussion of the prior art within this specification is to assist the  
addressee understand the invention and is not an admission of the extent of  
20 the common general knowledge in the field of the invention and is included  
without prejudice.

It is known in gaming systems to specify the proportion of what a player inputs  
to a game that is returned to that player i.e. a proportion of the revenue of a  
25 gaming machine. This measure is referred to as the Return to Player (RTP)  
amount and is expressed as a percentage of the player input i.e. as the RTP  
percentage. The RTP can be described as the proportion of the value input by  
a player that contributes to the prizes paid out by the machine. The specific  
value of the RTP is determined by the attributes of the gaming device itself i.e.  
30 the likelihood of a winning combination accruing within a specified time period.  
Where the gaming device is a so called a "pokie" or "fruit" machine, the RTP%  
is determined by the probability of the winning combinations of symbols  
occurring on the reels over a given time. The time over which the RTP% is

calculated is referred to as a cycle and is the number of plays of the game that would need to be played so that all possible sequences of symbols appear to the player.

5 While the RTP% represents the expected performance of a machine over a specified time period, the actual performance can vary within that specified period. The actual performance is termed the Actual Return To Player Percentage (ARTP%). The turnover (T) of a given gaming machine for a specified period is recorded in a turnover meter. Similarly, the total of the prizes paid out (P) for a machine is also recorded in a total payout meter. The  
10 ARTP% at any given time is the ratio of the turnover of a machine to the total of the prizes the machine has paid out over the specified period at that time.

In known gaming systems the RTP% is controlled by the manufacturer, operator or venue controller prior to gaming devices being available for play.  
15 The RTP% may be displayed to the players as required in some jurisdictions. The RTP% may be varied where gaming systems are provided with the functionality to enable the selection of the RTP%. In some cases this may be from a predetermined set of RTP% values (also known as variations). The  
20 manufacturer of the gaming system commonly determines such variations.

Gaming machines may be linked to other such machines to provide secondary gaming facilities such as a communal jackpot i.e. a jackpot that can be won by playing any one of an associated group of machines. The communal jackpot is  
25 available over and above the possible prizes from the base game being played on each individual machine. In this situation the revenue is split between the base game and the communal game. The manufacturers of the gaming system traditionally determine the proportion of the split.

30 One problem with the prior art arrangement is that some games provided by gaming machines are volatile. In other words the ARTP% varies significantly from the RTP% over the specified time period. As a result, the current performance of the machine may vary undesirably from the intended

performance. This can result in the machine not awarding prizes of the size or frequency that is expected or required by the gaming machine user or operator.

5 SUMMARY OF THE INVENTION

It is an object of the present invention to overcome or ameliorate at least one of the disadvantages of the prior art, or to provide a useful alternative.

According to a first aspect of the present invention there is provided a method  
10 for allocating a player's contribution in a gaming apparatus between a plurality of games, the method comprising the steps of:

- a) receiving a contribution from a user;
- b) splitting the contribution into a number of parts in accordance with a predetermined ratio;
- 15 c) allocating at least one of the parts of the contribution to one of the games; and
- d) modifying the predetermined ratio in response the measured performance of the gaming apparatus.

20 In some preferred embodiments the measure of performance is the ratio of designed performance and the actual performance. Preferably the performance is determined by the ratio of the revenue of the gaming apparatus and the value of prizes paid by the gaming apparatus. More preferably the modification of the ratio is proportional to the difference in  
25 designed performance and actual performance.

In another embodiment, the modified ratio  $I^n$  is determined in accordance with the formula

$$I^n = I^0 + \left[ \frac{RTP - T/P}{Q} \right]$$

30 where  $I^0$  is the base ratio, RTP is the designed performance, T is the revenue, P is the total prizes and Q is a control variable.

In a further embodiment, the predetermined ratio is modified periodically. In another embodiment the predetermined ratio is modified in real time. In another embodiment the predetermined ratio is modified in response to the  
5 occurrence of non-time base criteria.

In one preferred embodiment the predetermined ratio is modified within an upper limit. Preferably or alternatively the predetermined ratio is modified within a lower limit.

10

According to a second aspect of the present invention there is provided apparatus for allocating a player's contribution in a gaming apparatus between a plurality of games, the method comprising the steps of:

- a) input means for receiving a contribution from a user;
- 15 b) splitting means for splitting the contribution into a number of parts in accordance with a predetermined ratio;
- c) allocating means for allocating at least one of the parts of the contribution to one of the games; and
- d) control means operable in response to the measured performance of  
20 the gaming apparatus to modify the predetermined ratio.

According to a third aspect of the present invention there is provided apparatus for use with a gaming machine to control the proportion of a user's contribution to a game, the apparatus comprising:

- 25 performance measuring means operable to measure the performance of the gaming machine;
- control means operable in response to the performance of the gaming machine to modify the proportion of the user's contribution to the game,
- communication means for communicating the modified proportion to  
30 the gaming machine.

Unless the context clearly requires otherwise, throughout the specification the words "comprise", "comprising" and the like are to be construed in an inclusive

as opposed to an exclusive sense; that is to say, in the sense of "included, but not limited to".

#### BRIEF DESCRIPTION OF THE DRAWINGS

5 Preferred embodiments of the invention will now be described, by way of example only, with reference to the accompanying drawings in which:

Figure 1 is a schematic representation of a gaming system comprising gaming terminals;

10 Figure 2 is a schematic representation of the hardware associated with each of the gaming system of figure 1;

Figure 3 is a graph illustrating an example of the performance of one of the gaming terminals of figure 1; and

Figure 4 is a flow chart showing steps performed by the gaming machines of figure 1.

15

#### DETAILED DESCRIPTION

Figure 1 shows a gaming system 101 comprising a number of gaming machines 103 in communication with a system controller 105 via a network 107. The system controller 105 is also connected to a display 109. The  
20 system controller is also provided with a connection 111 to another system controller (not shown). Each gaming machine 103 comprises a screen 115 for displaying the game, which the terminal 103 offers, and a set of user controls 117 through which a user (not shown) inputs their choices in the running of the game. Each gaming machine also comprises a payment port 119 such as a  
25 coin slot or electronic card reader to enable the user to pay for the game to be played.

In return for a user submitting a suitable payment via the payment port 119 the gaming machine 103 enables the user to play a game of chance. The game  
30 may result in the user winning a prize. The likelihood of a gaming machine 103 awarding a prize for a particular game play is determined by the design of the game. The game is designed to pay out in prizes a percentage of what users pay in over a predetermined number of game plays i.e. the RTP%.

In the arrangement of figure 1, users are able to participate in two games that are linked. The first game provided by the gaming machines 103 as described above, and the jackpot controller 105 provides a second game. The second  
5 game is a communal jackpot built up from contributions from each of the gaming machines 103. The jackpot is incremented towards an upper limit in by the value of each contribution as it is received from the gaming machines 103 via the network 107. The jackpot controller 105 uses the display 109 to show the current value of the jackpot to the users of the gaming machines  
10 103. The jackpot controller 105 is arranged to award the jackpot prize when the jackpot value increments over an undisclosed threshold. The threshold is set randomly or pseudo randomly of initialization of the system controller 105 or after the system controller 105 is reset in response to the awarding of a previous jackpot.

15 Since the first game provided by the gaming machines 103 is linked to the second game provided by the game controller 105, the RTP% (which can be described as the money held aside from a user's payment to pay out prizes) is split between the first and second games. Each gaming machine 103 is  
20 arranged to split the RTP% from a game play in accordance with a predetermined ratio. The value of the RTP% that is allocated to the second game is communicated to the jackpot controller 105 via the network 107. This is the contribution referred to above that the jackpot controller 105 uses to increment the jackpot value. The jackpot is incremented by the value of the  
25 contribution i.e. the value of the RTP% allocated to the second game.

Figure 2 illustrates a part of the hardware of the gaming machine 103 and the jackpot controller 105. The split controller 200 is connected to a first game controller 201 which is in turn connected to a revenue input device 203 and a  
30 first accumulator 205. The first accumulator comprises two elements, a turnover meter 205a and a total prize payout meter 205b. The game controller 201 is also connected via the network 107 to a second game controller 207 in the jackpot controller 105. The game controller 207 is also connected to a



second accumulator 209, which is in turn connected to the display 109 (not shown).

The revenue input device 203 is operable to accept monetary input from a user in the form of coins or notes, tokens, payment card or other suitable form of payment. The revenue input device 203 indicates the amount of the payment to the game controller 201, which responds by adding the input value to the accumulator 205. The accumulator 205 uses the turnover meter 205a to record the total amount of revenue received via the revenue input device 203. The game controller 201 is the element in the gaming machine that actually runs the first game in response to user commands input via the control panel 117 (figure 1). The game controller also controls the paying out prizes for the first game as they are won and records such events in the total prize payout meter 205b. The game controller is also arranged to communicate the split of the RTP% to the second game controller 207. This communication also includes data that identifies to the second game controller 207 which of the gaming machines 103 has provided a given split of the RTP%.

The game controller 201 is also responsive to signals from the split controller 200 to modify the RTP% split between first and second games. The split controller 200 is arranged to monitor the performance of the game being provided by the first game controller 201. The split controller 200 periodically reads the contents of the meters 205a and 205b and uses the contents to determine the ARTP% for the game. The ARTP% is then compared to the RTP% and results of this comparison used to generate a control signal to the game controller. The game controller uses the received control signal to modify the split of RTP% between the first and second games. The modification is arranged to reduce any divergence between the ARTP% and the RTP%. The operation of the split controller 200 will be described in further detail below.

The second game controller 207 responds to the signals from the first game controller by adding the indicated RTP% split value to the accumulator 209

and updates the display 109 (figure 1) with the revised jackpot value. The second game controller 207 is the element of the jackpot controller 105 that runs the second game. In other words, the game controller 207 sets the non-disclosed threshold value at which the jackpot will be paid out, receives  
5 signals from the gaming machines and updates the accumulator 209 and the display 109 with that value.

The game controller 207 initiates a prize payout when a received RTP% split value added to the accumulator 209 causes the jackpot to meet or exceed the  
10 payout threshold. When this occurs the game controller 207 identifies which of the gaming machines 103 triggered the jackpot and sends a signal to the identified machine. The gaming controller 201 of the identified gaming machine 103 responds to this signal by indicating to the user that the jackpot has been awarded and paying out the jackpot amount. In response to a  
15 jackpot award occurring the game controller 207 also resets the jackpot value and generates a new payout threshold before receiving further signals from the gaming machines 103 and incrementing the jackpot value in the accumulator 209 accordingly.

20 It should be noted that prizes paid out for the second game by the first game controller 201 are also recorded in the total prize payout meter 205b. These prize values are required for the calculation of the ARTP% for the gaming machine 103. In other words, the RTP% for a given machine is a combination of the winnings from both the first and second games.

25

Figure 3 is a graph illustrating the RTP% and ARTP% values over a specified period ( $t$ ) for a typical gaming machine and for one of the gaming machines 103. For both machines the RTP% 301 remains constant over time while the ARTP% 303, 305 for each machine varies. As a result, at any given time  
30 within the specified period  $t$  the ARTP% 303, 305 may be different from the RTP% 301. However, as a result of the modifications to the split made by the first game controller 201 in response to the signals from the split controller 200, the variation of the ARTP% 303 for the gaming machines of the present

embodiment is reduced.

The operating process of one of the gaming machines 103 will now be described with reference to the flow chart of figure 4. At the first step 401 the gaming machine has just been switched on for the first time. In other words, the machine has just been commissioned and the accumulator 205 and its meters 205a, 205b are set to zero. The process holds at step 401 until a user inputs some monetary value at which point processing moves to step 403.

At step 403, a timer is checked to determine whether a predetermined period as elapsed. The predetermined period defines the frequency with which the split controller 200 monitors the ARTP% and modifies the split parameters accordingly. When the gaming machine has just been set up, the timer is set to an extended period. This extended period is designed to keep the split controller 200 inactive while the gaming machine establishes significant data in the meters 205a, 205b. If either the extended or the standard preset period has not expired processing continues to step 409 which is described in more detail below.

If when the processing moves to step 403 the period has elapsed then processing moves to step 405. At step 405 the ARTP% is calculated by obtaining the total revenue to date and the total prizes paid to date from the respective meters 205a, 205b. These figures are then used to calculate new split parameters in accordance with formula 1 below.

25

$$I^n = I^0 + \left[ \frac{RTP - T/P}{Q} \right]$$

Formula 1

30

In formula 1,  $I$  is the base RTP% split value or ratio that is allocated to the

second game,  $n$  is the modification iteration,  $RTP$  is the RTP% of the game,  $T$  is the total revenue to date,  $P$  is the total prizes to date and  $Q$  is a variable. Initially,  $I$  is set to 2% and  $Q$  is set to 10.

- 5 The result of the calculation in step 405 is a modified allocation of RTP% to the second game in response to the difference between the RTP% of the game and the actual performance i.e. the ARTP%. In other words, if the ARTP% is greater than the RTP% then a lesser proportion of the RTP% is allocated to the second game and visa versa. This has the effect of mediating  
10 the ARTP% towards the expected RTP%. Table 1 below shows some examples of the application of formula 1.

Modification Iteration	Current Allocation of RTP% to Second Game	RTP%	ARTP%	Difference	New Allocation
1	2%	90.5%	92%	-1.5%	1.85%
2	1.85%	90.5%	91%	-0.5%	1.95%
3	1.95%	90.5%	90%	0.5%	2.05%
4	2.05%	90.5%	89%	1.5%	2.15%
5	2.15%	2.095%	91.5%	-1.0%	1.9%

Table 1

- 15 As can be seen from Table 1 above, the formula acts to reduce the allocation to the second game from the initial value of 2% when the ARTP% is greater than the RTP%. However, when the situation is reversed and the difference becomes positive, the formula begins to increase the allocation. Once the new  
20 allocation has been calculated, the processing moves to step 407 at which the game controller 301 updates its RTP% split parameters in accordingly and processing moves to step 409.

- 25 At step 409 the gaming controller starts the game play sequence and while the game is in progress processing continues to step 411. At step 411 the meter 205a is updated with the value paid by the user for the game in progress and processing moves to step 413. At step 413 the gaming controller

extracts from the accumulator the appropriate value of the split RTP% for the second game in accordance with the split parameters. The split parameters are either the preset values or may have been modified in step 407 above. This value is then signaled to the second game controller in combination with  
5 an indication of the identity of the current gaming machine.

Processing then moves to step 415 where it is determined whether a jackpot prize is due in response to any return signal from the second game controller 207. If a prize is due then processing moves to step 417. At step 417 the prize  
10 is paid and process then moves to step 419 and the meter 205b is updated with the value of the prize. If no jackpot prize signal arrives from the second gaming controller 201 before the end of the game play of the first game then processing moves from step 415 to step 419.

15 At step 419 it is determined whether a prize is due as a result of the end sequence of the current first game play. If a prize is due then processing moves to step 421 where the prize is paid and the process moves to step 423. At step 423 the meter 205b is updated to take into account the prize paid out. If no prize results from the game play then processing moves straight from  
20 step 419 to step 425.

At step 425, the gaming controller 201 establishes whether enough credit remains for a further game play and if not processing moves to step 401 where the user is prompted to input more credit. If at step 425 sufficient credit  
25 remains then processing moves to step 403 and continues as described above for that step.

In the embodiment described above the allocation of RTP% to the second game is initially set at 2%. If in some situations a game was particularly  
30 volatile it might be desirable to set limits to this allocation. In a further embodiment, the allocation is set with an upper limit or a lower limit, for example 3% and 1% respectively. In further another embodiment both upper and lower limits are in applied. Also, in the embodiment above, the control

variable Q is set to 10. This variable acts to control the size of the modification to the base RTP% allocation to the second game. Increasing Q results in a greater change to the split to the second game in response to the ARTP%. Decreasing Q has the opposite effect. The Q variable can be used to tune the system for prevailing conditions.

In some embodiments the split controller may be modified to operate in real time i.e. to monitor the ARTP% constantly and update the split parameters accordingly. In other embodiments the split controller may be arranged to monitor the ARTP% and modify the split parameters in response to non-time based criteria such as in response to prizes being paid out, a predetermined number of games having being played or for a given amount of revenue being generated. In some embodiments the split controller may be arranged to operate a random or pseudo-random intervals. In other embodiments, both time based and non time based triggers may be used. In one embodiment, the frequency of the operation of the split controller is determined by the magnitude of the difference between the RTP% and the ARTP%.

As will be understood by those skilled in the art, there will be other known formula that could be used in place of formula 1 which would have the effect of moderating the volatility of a given game. Such other smoothing formulae are well known. In some embodiments predictive algorithms may be used to predict the ARTP% in the short term in order to provide the modified split of RTP% to the second game.

As a post-manufacture addition to a gaming system, embodiments of the present invention may extend the life of a gaming machine. This may be particularly applicable in a situation where a volatile game has not had enough play time to complete it's play cycle and thus perform to the expectations of the operator. Attaching an embodiment of the invention to such a volatile game would provide a compensating effect.

It will be understood by those skilled in the art that the apparatus that

embodies a part or all of the present invention may be a general purpose device having software arranged to provide a part or all of an embodiment of the invention. The device could be single device or a group of devices and the software could be a single program or a set of programs. Furthermore, any or  
5 all of the software used to implement the invention can be communicated via various transmission or storage means such as computer network, floppy disc, CD-Rom or magnetic tape so that the software can be loaded onto one or more devices.

10 Although the invention has been described with reference to specific embodiments, it will be appreciated by those skilled in the art that it may be embodied in other forms.

DATED this 26<sup>th</sup> day of February 2004

15 BALDWIN SHELSTON WATERS

Attorneys for: PALTRONICS AUSTRALASIA PTY LTD

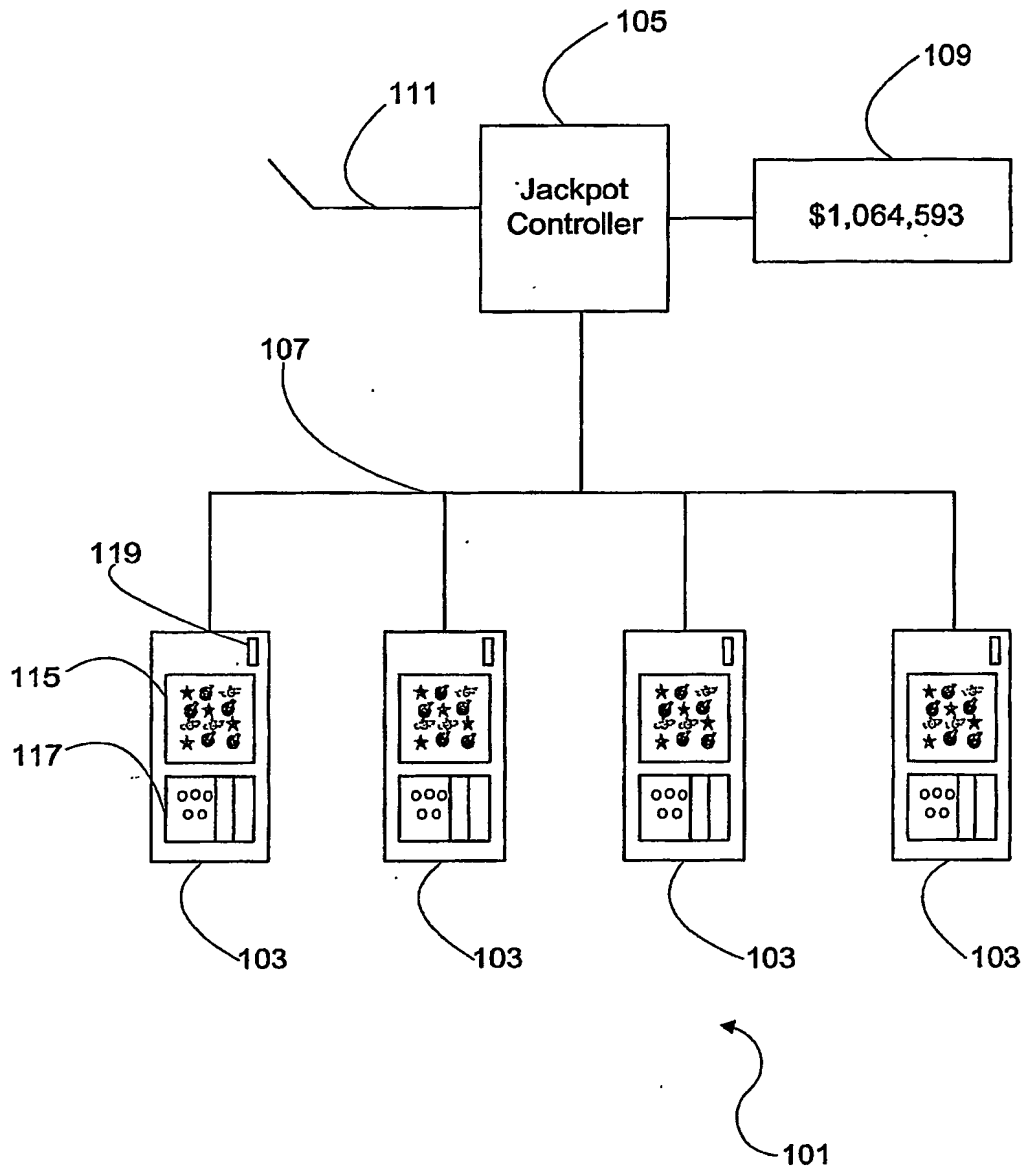

Figure 1



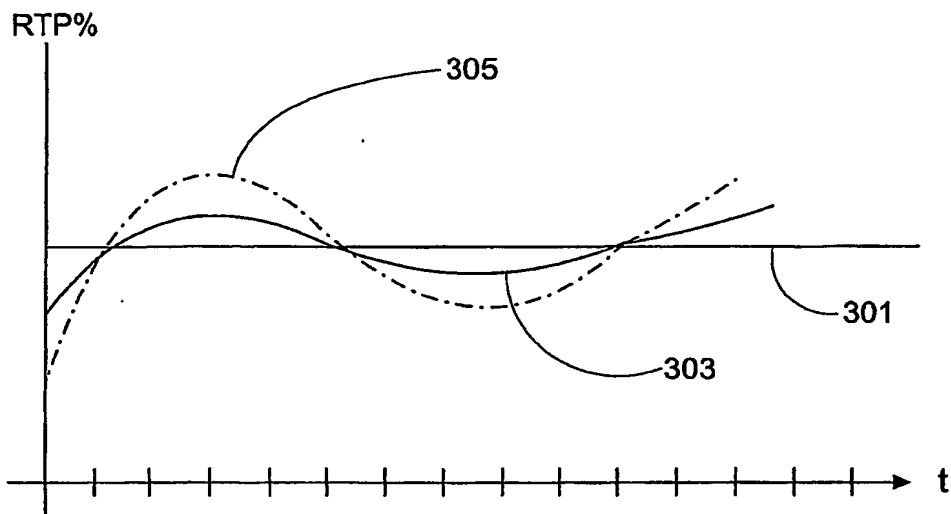

Figure 3

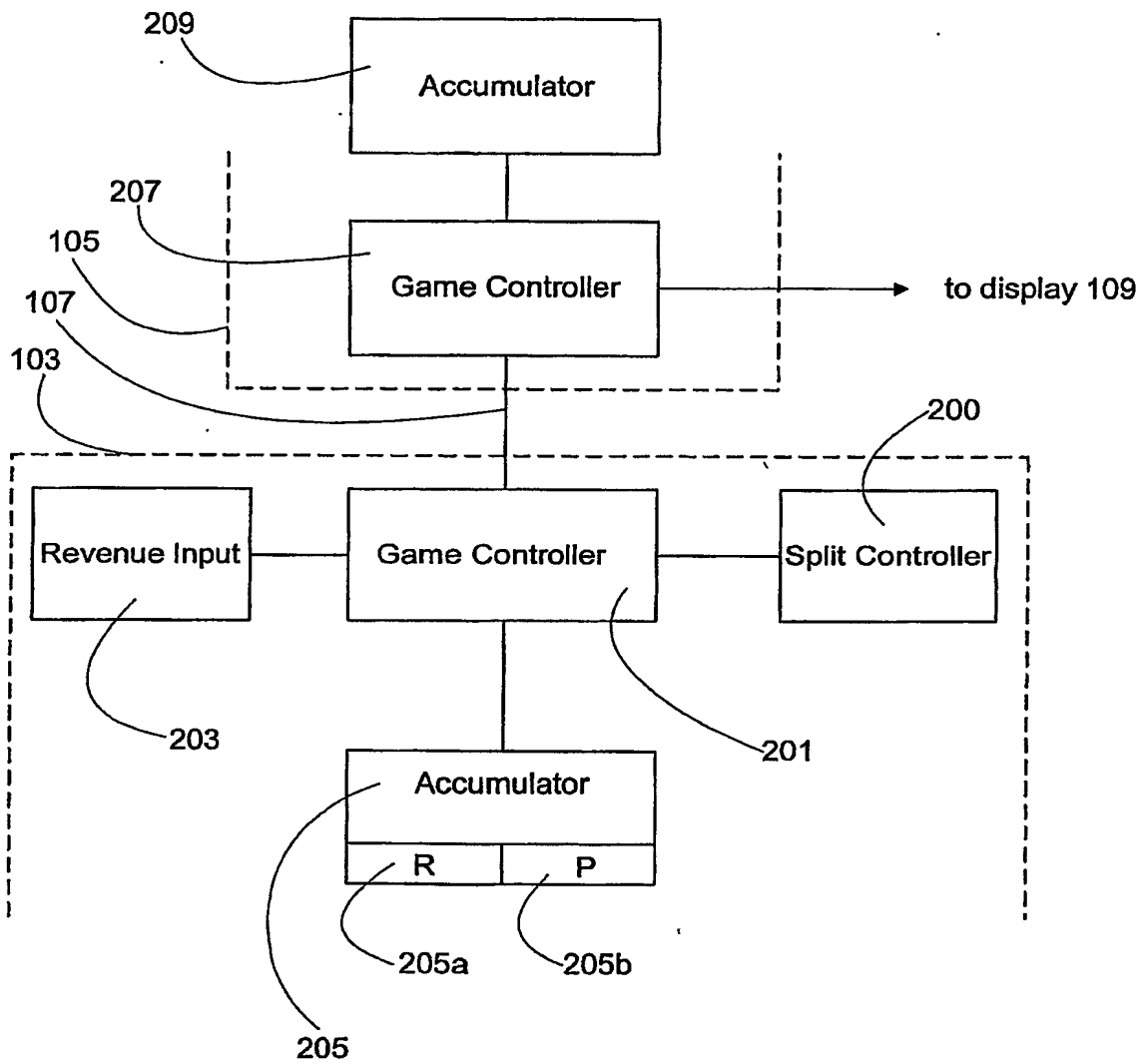

Figure 2

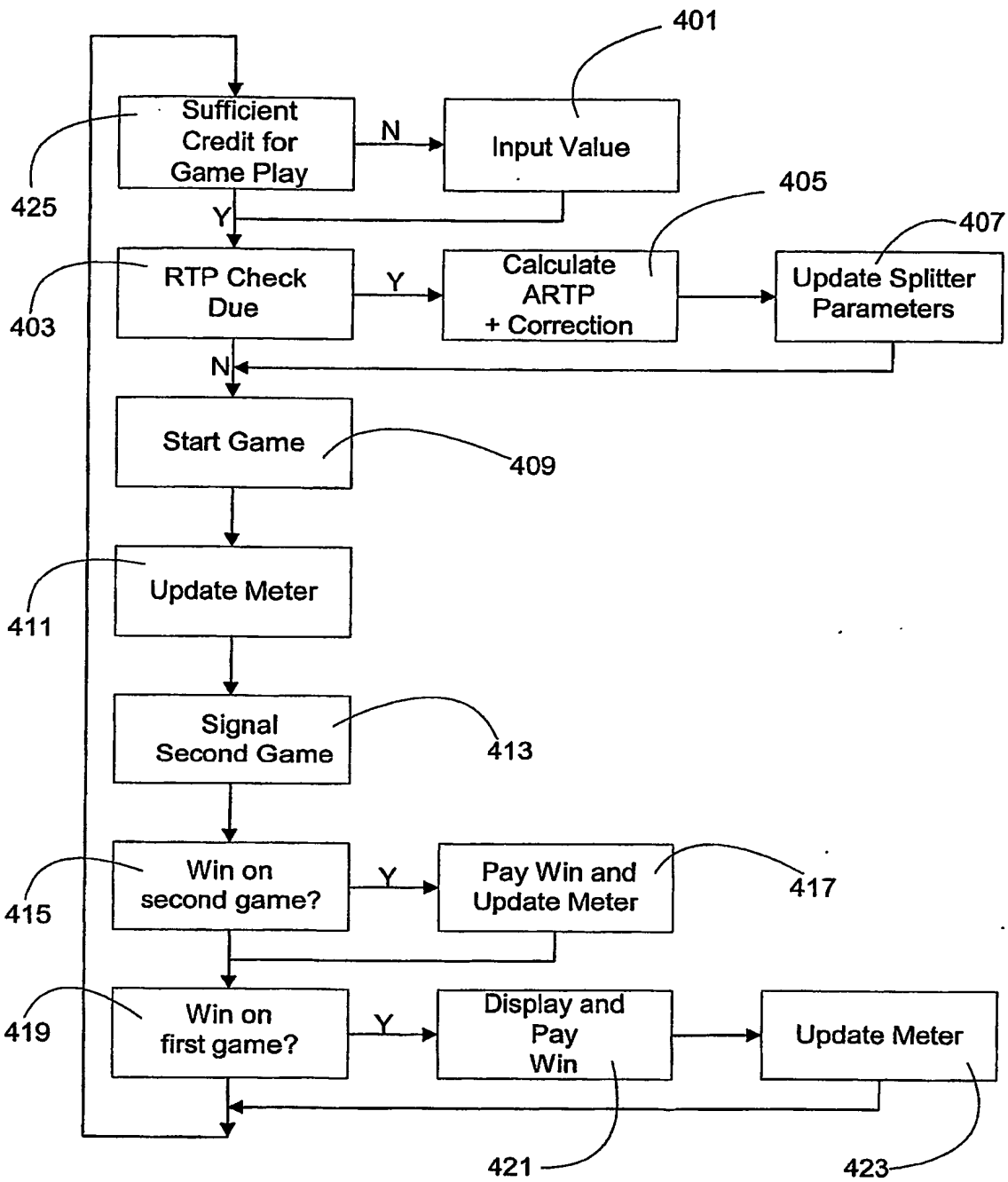

Figure 4